

bZ4X Touring

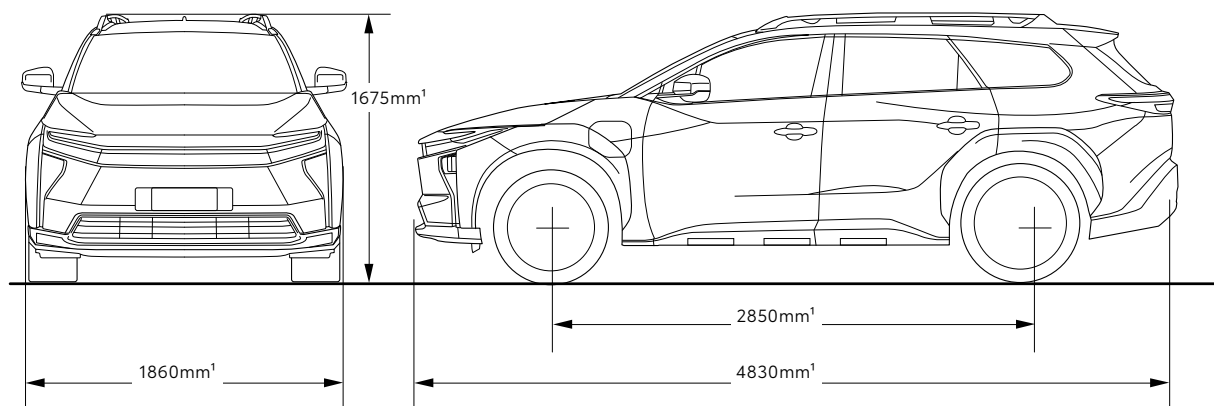

Please Note: information is accurate as at May 2026.

Specification and imagery are indicative and should only be used as a guide. Vehicle and accessory specification, features, colour and trim may differ at the time of vehicle delivery.



MECHANICAL SPECIFICATIONS		bZ4X Touring	
ELECTRIC MOTOR	Type	Permanent Magnet Synchronous Motor	
	Maximum (kW)	Front motor	167
		Rear motor	167
	Maximum output – system (kW)		280
	Model code front/rear (AWD)		2XM
	Max torque (Nm)	Front	268.6
Rear		268.6	
BATTERY AND CHARGING	Battery type		Lithium-ion battery
	Number of battery cells		104
	Voltage per cell		3.76
	Total voltage (V)		391
	Traction battery capacity (Ahr)		191
	Battery Capacity (kWh) – Gross		74.7
	Mode 2 and Mode 3 charging cables		Included
	AC charging ² – 10-100%	7kW Single-Phase charging	approx. 9 hours 30 mins
		11kW 3-Phase charging	approx. 7 hours
		22kW 3-Phase charging	approx. 3 hours 30 mins
	150 kW DC charging ² – 10-80%		approx. 30 mins
	AC Input – standard		Type 2
	DC Input – quick charge		CCS2
Max AC charging power (kW)		22	
DC charger maximum output (kW)		150	
STEERING	Gear type		Rack and Pinion
	Type		Electric Power Steering
	Lock to lock		2.81
SUSPENSION	Front		MacPherson strut
	Rear		Double wishbone
	Stabilizer bar – front and rear		Torsion bar
BRAKES	Type – front and rear		Ventilated disc brake
	Front diameter		17" Disc
	Rear diameter		17" Disc
	Regenerative braking system with paddle control		•

bZ4X GRADE		bZ4X Touring
DRIVETRAIN AND TRANSMISSION	Transaxle model code (Front/Rear)	QK10 / QL10
	All Wheel Drive	•
	Final drive gear ratio	12.363
	Type	BEV automatic transmission
WEIGHTS AND CAPACITIES (APPROXIMATE)	Seating capacity – persons	5
	Cargo capacity (VDA) (Max) (L)	603
	Gross vehicle weight (kg)	2560
	Maximum curb weight (kg)	2065
	Running ground clearance ³ (mm)	211
	Braked towing capacity ⁴ (kg)	1500
	Unbraked towing capacity ⁴ (kg)	750
WHEELS	Design and size	20" Alloy wheels with aero inserts
	Tyre repair kit	•
PERFORMANCE	Maximum speed (km/h)	180
	Acceleration 0 to 100km/h	4.4
	Minimum turning radius (m)	Tyre = 5.6 / Body = 6.1
	BEV driving test range ⁵ (km) – Actual driving range can be significantly less than test driving range, depending on various factors	488 (WLTP) ⁵
	Electric energy consumption ⁵ (Wh/km)	168 (WLTP)
COMFORT AND CONVENIENCE	Dual-zone climate control auto air conditioning	•
	Nanoe™ ⁶ X air conditioning technology	•
	Rear air vents	•
	Electric Park Brake with Brake Hold	•
	Automatic rain sensing wipers	•
	Key Reminder Alert	•
	Driver power passenger front seat with memory – 8-way	•
	Heated front and rear seats	•
	Ventilated seats – driver and passenger	•
Cupholders – 2x front, 2x rear	•	
EXTERIOR	LED Daytime Running Lamps	•
	Heated exterior mirrors with puddle lights	With memory and reverse auto adjust
	Headlamp cleaner	•
	LED Headlamps with Adaptive High Beam System	•
	LED rear and eye level brake lights	•
	LED side mirror indicators	•
	Rear fog lamps	•
	Rear, side, quarter and back privacy glass	•
	Ladder style roof rails	•
	Rear spoiler	•
	Front and rear air spats	•
	Resin black wheel arches and bonnet insert	•

bZ4X GRADE		bZ4X Touring
INSTRUMENTS AND CONTROLS	Intelligent Parking Assist	•
	7" colour Multi Information Display (MID)	•
	Digital rear view mirror	•
	Auto retractable door mirrors	•
	Power back door with kick sensor ⁷	•
	Heated steering wheel, audio, phone, MID, and Toyota Safety Sense controls	•
	12V socket	•
	Smart entry and smart start	•
	2x USB-C Ports (Front) in centre console storage	•
	2x USB-C rear centre console	•
	2x wireless phone charger ⁸	•
	Voice assistant	•
	Vehicle Stability Control	•
	Downhill Assist Control, Multi Terrain Sensing and Crawl Control	Accessible through X-Mode
	3 off-road modes (X-Mode)	•
Tilt and telescopic steering wheel adjustment	•	
INTERIOR	Vehicle-to-Load (V2L) ⁹ – AC Inverter 220V/1500W	•
	Centre tray	•
	Interior seat trim	Premium SofTex ^{®6}
	Heated steering wheel	•
	Rotary dial shift with integrated park brake	•
	60:40 folding rear seats	•
	Digital rear view mirror	•
	Personal front LED reading lamp	•
	Luggage compartment light	•
	Fixed panoramic moon roof	•
MULTIMEDIA	9-speaker JBL ^{®6} premium sound system	•
	14" multimedia system with embedded navigation	•
	Digital Audio Broadcast	•
	Wireless Apple CarPlay ^{®10} and Wireless Android Auto ^{™,10}	•
SAFETY AND SECURITY	8x SRS Airbags	•
	Toyota Safety Sense ¹¹ – including All-speed Active Cruise Control with curve speed reduction, Lane Departure Alert with steering assist, Lane Trace Assist, Pre-Collision Safety system with pedestrian and daylight cyclist detection, Emergency Steering Assist, Road Sign Assist (speed signs only), Automatic High Beam and Emergency Driving Stop System	•
	Blind Spot Monitor with Safe Exit Assist	•
	Rear Cross Traffic Alert	•
	Driver Monitor Camera	•

bZ4X GRADE		bZ4X Touring
SAFETY AND SECURITY CONTINUED	Panoramic View Monitor	•
	Parking Support Brake with parking sensors	•
	Anti-lock Braking System with Electronic Brake-force Distribution and Brake Assist	•
	Rear seat occupant reminder	•
	Seatbelt reminder – all seats	•
	2x ISOFIX child restraint anchorage points – rear outboard seats	•
	First Aid kit	•
TOYOTA CONNECTED SERVICES ^{12,13,14}	Toyota Essentials Emergency	Complimentary until Telstra 4G sunset or termination of services in accordance with our T&Cs
	Toyota Essentials	Complimentary until Telstra 4G sunset or termination of services in accordance with our T&Cs
	Toyota Connect+	1 year complimentary access – Fees apply thereafter. Subject to Telstra 4G sunset or termination of services in accordance with our T&Cs
	Toyota Connected Multimedia	1 year complimentary access – Fees apply thereafter. Subject to Telstra 4G sunset or termination of services in accordance with our T&Cs

- Weights/mass/volumes/dimensions are approximate and subject to individual vehicle variances, and should be confirmed before fitting any accessories, towing or otherwise relying on this value.
- Charging duration is approximate only and may vary depending on environmental and charging conditions, type of charger and method used. Actual charging times may differ. Frequent use of DC fast charging can impact battery performance and durability. Toyota recommends minimising DC fast charging usage. DC fast charging speed will reduce after the battery is charged to 80%. Refer to Owner's manual and toyota.com.au/explore/electrified/charging-your-toyota for guidance.
- Dimensions are approximate and are subject to individual vehicle variances, accessory fitment and weight carried.
- Maximum vehicle braked towing capacity is subject to state and federal regulatory requirements. Before towing, customers should consider the vehicle's limitations, including towing capacity specifications, gross vehicle mass (GVM), gross combined mass (GCM), kerb weight specified by the manufacturer, and ensure that individual front and rear axle load limits are not exceeded as also specified by the manufacturer. Vehicle payload calculation is GVM less kerb weight or as otherwise specified in the vehicle owner's manual. Actual payload is affected by any added load to the vehicle, including the number of occupants, luggage, accessories, and tow ball download weight. It is important to consider the actual payload, to ensure the fully loaded vehicle remains within the specified GVM limits. For more details, please refer to the vehicle's Owner's Manual/ Toyota Basic Towing Guide or consult your authorised dealer. Toyota recommends use of a Load Distribution Hitch (LDH) when towing loads greater than half of the vehicle's GVM or as specified in the Owner's Manual. Based on road conditions, a LDH may not be suitable. Refer to [Toyota Basic Towing Guide](#). Toyota Genuine LDH sold separately at additional cost. Warranty conditions apply. Refer to [Toyota Warranty Advantage Guide](#).
- Results were achieved under test conditions and do not reflect the driving range in real world driving. Results achieved for battery electric bZ4X Touring Electric SUV is based on consumption rate of 168 Wh/km using the Worldwide Harmonised Light Vehicle Test Procedure (WLTP) accepted by the ADR 81/02 (displayed on the Energy Consumption label affixed to the car). The electric range and the energy consumption values were determined using a fully charged battery in a laboratory test and are not reflective of real world driving. Actual driving range may vary depending on accessories fitted, battery age and condition, climate, driving style, use of heating/cooling, traffic conditions, and vehicle load. For more information, please visit toyota.com.au/explore/electrified/faqs

- Product and company names are trademarks of their respective owners.
- Fitment of towbar requires deactivation of the kick boot sensor feature. Towing capacity subject to regulatory requirements, tow bar and vehicle design and towing equipment limitations. Ask your Dealer for Toyota Genuine tow bar capacity and availability details.
- Only Qi-supported devices compatible. Refer to device manufacturer. May require additional purchase of accessory to support wireless charging.
- Vehicle to Load (V2L) supports electrical devices with a combined power consumption of up to 1500W at 220 VAC. V2L does not support Vehicle to Home (V2H) or Vehicle to Grid (V2G) charging. V2L is powered using the high voltage battery and extended use will decrease driving range. Never leave the vehicle unattended when using the V2L system. Refer to Owner's Manual for guidance.
- CarPlay® is a trademark of Apple, Inc. registered in the U.S. and other countries. Android Auto™ is a trademark of Google LLC.
- Driver assist feature. Only operates under certain conditions. Check your Owner's Manual for explanation of limitations. Please drive safely.
- See toyota.com.au/services/connected/terms-conditions for T&Cs.
- Complimentary periods commence upon delivery date. Fees may apply there after. Not available outside Australia, if services disabled or terminated or after Telstra 4G sunset. Dependent on enabled DCM, GPS signal strength, mobile network coverage, mobile app data (at user's cost), enabled push notifications and other factors outside Toyota's control which can limit ability or functionality of system. Check your Owner's Manual or toyota.com.au/services/connected for explanation of limitations. Please drive safely.
- The myToyota Connect App supports vehicles with a Build date from 2009 onwards, with or without Toyota Connected Services. Requires compatible device and app installation, mobile data (at user's cost), Australian network reception, GPS signal, enabled push notifications and other factors outside Toyota's control which can limit functionality. Features vary by model and may change. See toyota.com.au/services/connected for more information.

IMPORTANT NOTICE – PLEASE READ:

Toyota Australia uses its best endeavours to ensure material is accurate at the time of publishing. All information must be confirmed with your Toyota Dealer at the time of ordering, as specifications, applicability and availability may change over time. Colours depicted are a guide only and may vary from actual colours due to the printing/display process. Toyota Australia reserves the right to change and/or discontinue, without notice, models, prices, colours, materials, equipment, specifications. To the extent permitted by law, Toyota Australia will not be liable for any damage or loss incurred from relying

on the information and images contained in this material. Distributed nationally (other than in Western Australia) by Toyota Motor Corporation Australia Limited ABN 64 009 686 097. Material distributed in Western Australia by or on behalf of Prestige Motors Pty Ltd (for vehicles) and by Eastpoint Pty Ltd (for parts/accessories). Toyota Australia makes no warranties regarding (and will not be liable for) accuracy of materials distributed in Western Australia. PROOF HQ: T2026-023146. GTP-009807. VERSION: MAY 2026.