



SITRAK

G7S 8X4 TIPPER



(Reference Photo)

EXTERNAL DIMENSIONS

Length(mm)	9092
Width(mm)	2492
Height(mm)(empty)	3471
Wheel base(mm)	1800+3400+1400
Wheel track(mm)	Front 2045 Rear 1872
height of fifth wheel ground clearance (mm)	0
Approach angle(°)	16
Departure angle(°)	24
Front overhang(mm)	1492

FEATURES

- **Reliable MC13.54-61TD engine.**
- **12 Speed ZF AMT gearbox.**
- **Comfortable cab for operator comfort.**
- **Bosch steering pump /LCD Color display/ WABCO brake control/Voss connector.**
- **Differential locks and cross locks for when the going gets tough.**
- **Alloy rim/air tank to reduce tare weight.**
- **EBS/ACC/AEBS/HAS/FCWS/WABCO Radar/ 360-degree surround view.**
- **The new G7S offers you flexibility configurations to meet your transportation requirements.**



G7S 8X4 TIPPER

SITRAK

WEIGHTS

GVM (kg)		31000
Max load of two axles (kg)	Front	6500/6500
	Rear	18000
GCM (kg)		75000

CAPABILITY

Max speed(km/h)	100
Min turning diameter (m)	22.6
Max climb gradient (%)	35
Fuel tank (L)	600L

CABIN

Model	G7S-P
Sits	2
Turning radius (mm)	2807

ENGINE

Model	MC13.54-61 TD
Displacement (L)	12.42L
Power rating kW/(r/min)	400/1800
Max torque Nm/(r/min)	2500/1000~1400

TRANSMISSION

Model	ZF 12TX2621TD
Forward gear ratio	16.688, 12.924, 9.926, 7.688, 5.895, 4.565, 3.655, 2.831, 2.174, 1.684, 1.291, 1.000
Reverse gear	15.537, 12.033

FRAME

Model	ladder framework	
Main beam cross-section (mm)	C type 300×80×8	
Width of frame Assembly(mm)	Front	940
	Rear	850

DRIVING AXLE

Model	MCY11BES	
Redactor ratio	Ratio	3.08
	Optional	
Differential lock	interwheel & interaxle diff. lock	

FRONT AXLE

Model	VPD71DS
-------	---------

SUSPENSION

Front	Model	Non-independence
	Number	3 leaf parabolic
Rear	Model	Non-independence
	Number	8 air bag

STEERING GEAR

Model	Recirculating ball hydraulic power
Ratio	17 ~ 20:1
Max pressure of pump (kPa)	18300
Steering way	Steering wheel

BRAKING SYSTEM

Working pressure (kPa)	1250
Drive braking type	Dual circuit
Brake power adjust type	EBS ESC HSA
Parking brake type	Spring stored energy air cut brake
Assistant brake type	Jake Engine Brake

ELECTRICS

Circuit type	double, control positive pole
Voltage (V)	24
Generator power (kW)	3
Accumulator voltage / capacity(V/Ah)	2x12/240

EXTRAS

Trailer brakes ABS to rear	Included
Sun visor, side skirts	Included



SITRAK

G7S 8X4 TIPPER

010230103027

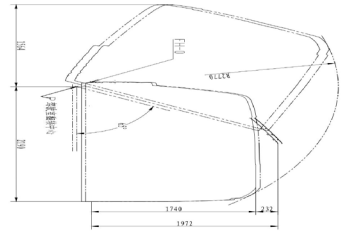
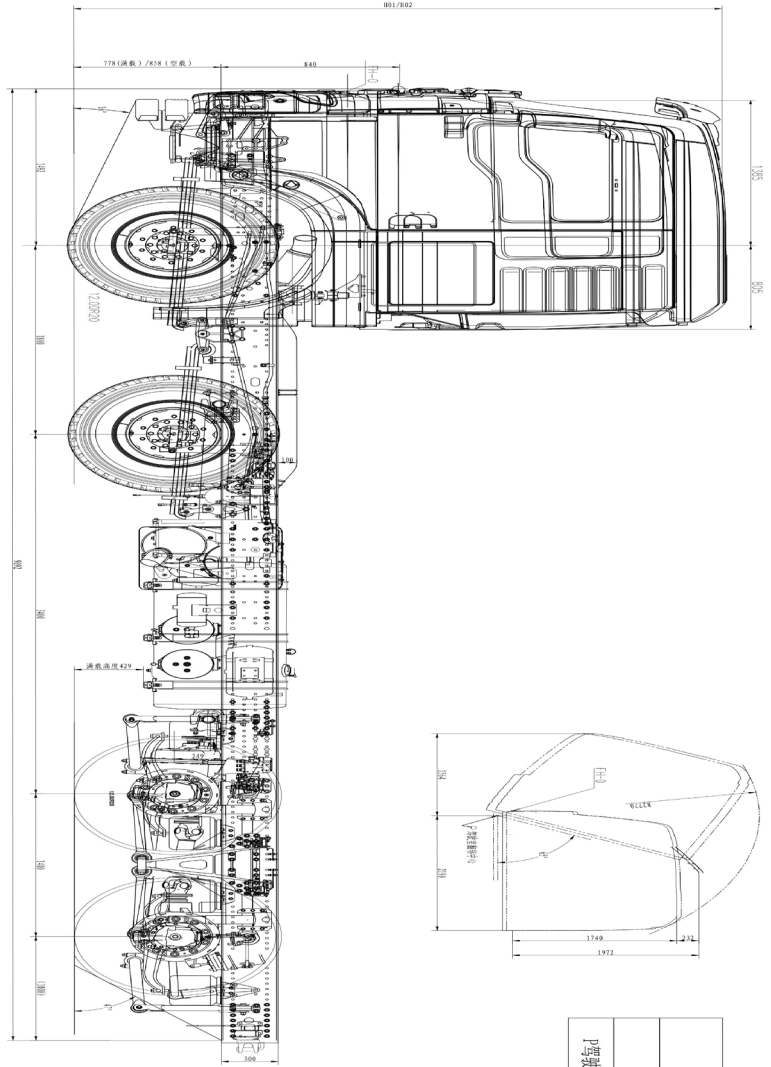

整车高度		驾驶室坐标 (-1475, 0, 840)
空载01	3380	
满载02	3450	
P驾驶室		

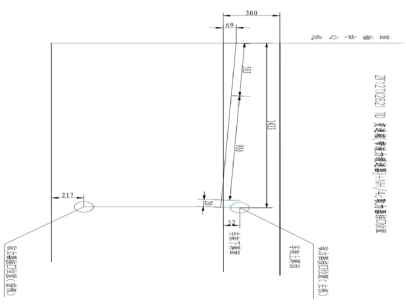
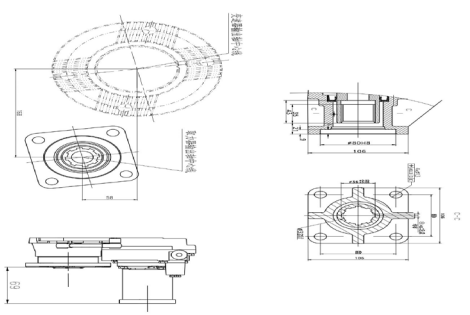
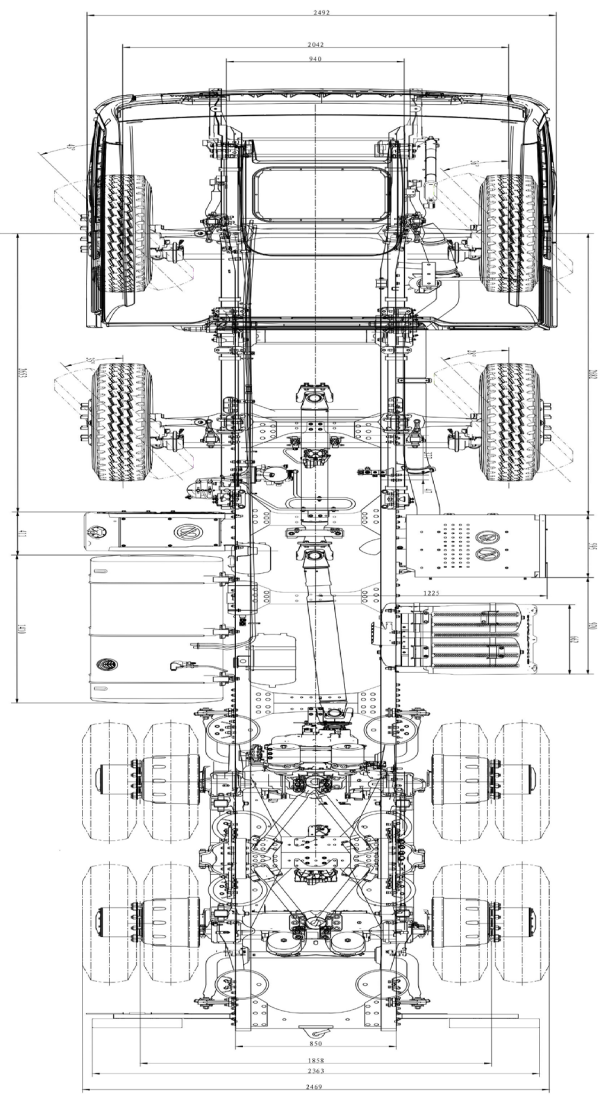

1	2	3	4	5	6	7	8	9	10	11	12	13	14	15	16	17
---	---	---	---	---	---	---	---	---	----	----	----	----	----	----	----	----

1	2	3	4	5	6	7	8	9	10	11	12	13	14	15	16	17
---	---	---	---	---	---	---	---	---	----	----	----	----	----	----	----	----

名称	规格
车架	CS-2车架
发动机	ISL3500
变速箱	2100R20 9速机械变速箱
驱动桥	2100R20 9速机械变速箱
转向桥	2100R20 9速机械变速箱
制动	2100R20 9速机械变速箱
悬架	2100R20 9速机械变速箱
轮胎	2100R20 9速机械变速箱
其他	2100R20 9速机械变速箱