

# RENAULT MASTER



overseas model shown





# the van that simplifies everyday life

Available in three lengths, two heights, and in front-wheel drive or rear-wheel drive, you'll have no trouble finding a Master to suit your business.



overseas model shown

## Enjoy your work life with a comfortable cabin and a practical cargo area

**FWD or RWD  
MT or AUTO**

**comfortable  
and practical  
cabin**

**cargo bay  
volume from  
10.8m<sup>3</sup> to 17m<sup>3</sup>**

**a suite of advanced  
driver-assistance  
systems**



# **interactive menu**

**01. design**

**02. interior space**

**03. modularity**

**04. engines**

**05. advanced driver  
assistance systems**

**06. customisation**



# robust and high-status

**With a dynamic front-end design featuring signature C-shaped LED daytime running lights, Renault Master has a bold personality and is the ideal partner to grow your business.**



overseas model shown

**configure →**



## 02. interior space

# useful and practical

**Renault Master's cabin combines design, comfort and functionality. Perfect for long days on the road, it's the ideal mobile office.**



overseas model shown

mobile office: back of the central folding seat designed to hold your folders or computer

**There are plenty of storage compartments throughout the cabin.**



overseas model shown

door pocket storage

**configure →**



### 03. modularity

## easy and secure loading

Load bulky items easily thanks to rear doors that open up to 270°, and secure your goods with multiple anchorage points throughout the cargo area.



overseas model shown

270° rear opening\*

With its rear and side openings and loading volume (10.8m<sup>3</sup> to 17m<sup>3</sup>), Renault Master adapts to the lives of professionals on a daily basis.



overseas model shown

handle located behind the bulkhead

[configure →](#)



## 04. engines

# front or rear-wheel drive

**Renault Master front-wheel drive<sup>(1)</sup> is highly capable and comfortable to drive.**



front-wheel drive chassis

**If you are looking for a higher payload and enhanced traction, opt for the rear-wheel drive version<sup>(2)</sup>.**

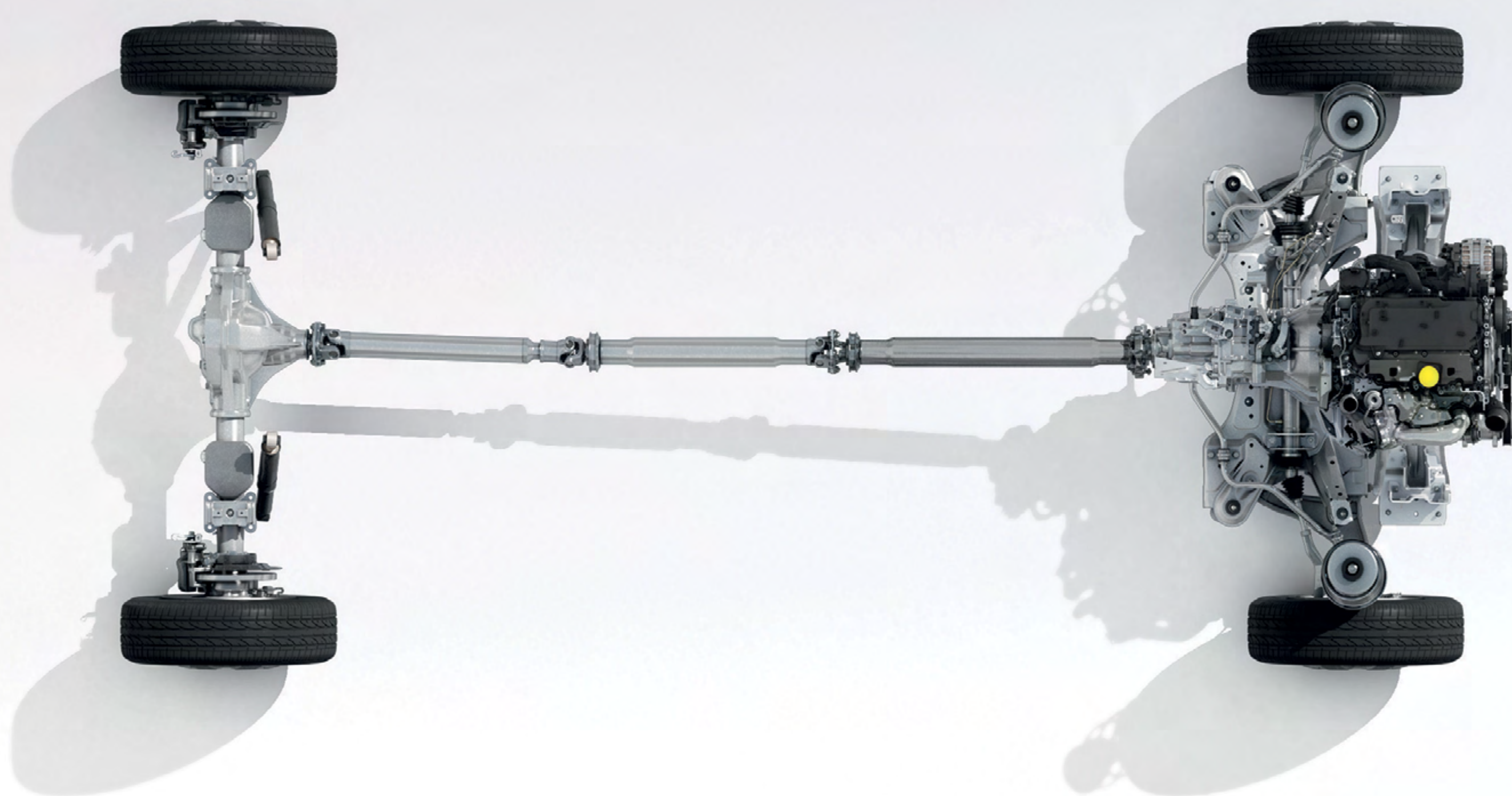

rear-wheel drive chassis

(1) GVM of 3,510 kg on FWD van variants  
(2) GVM of 4,495 kg on RWD van variants.

**configure →**



## 05. advanced driver assistance systems

# a suite of advanced driver assistance systems

## Renault Master is equipped with innovative advanced driver assistance systems.



### smart rear-view mirror\*

Using a rear-mounted camera, it provides excellent medium and long-distance vision of the surroundings via an in-cab digital display.

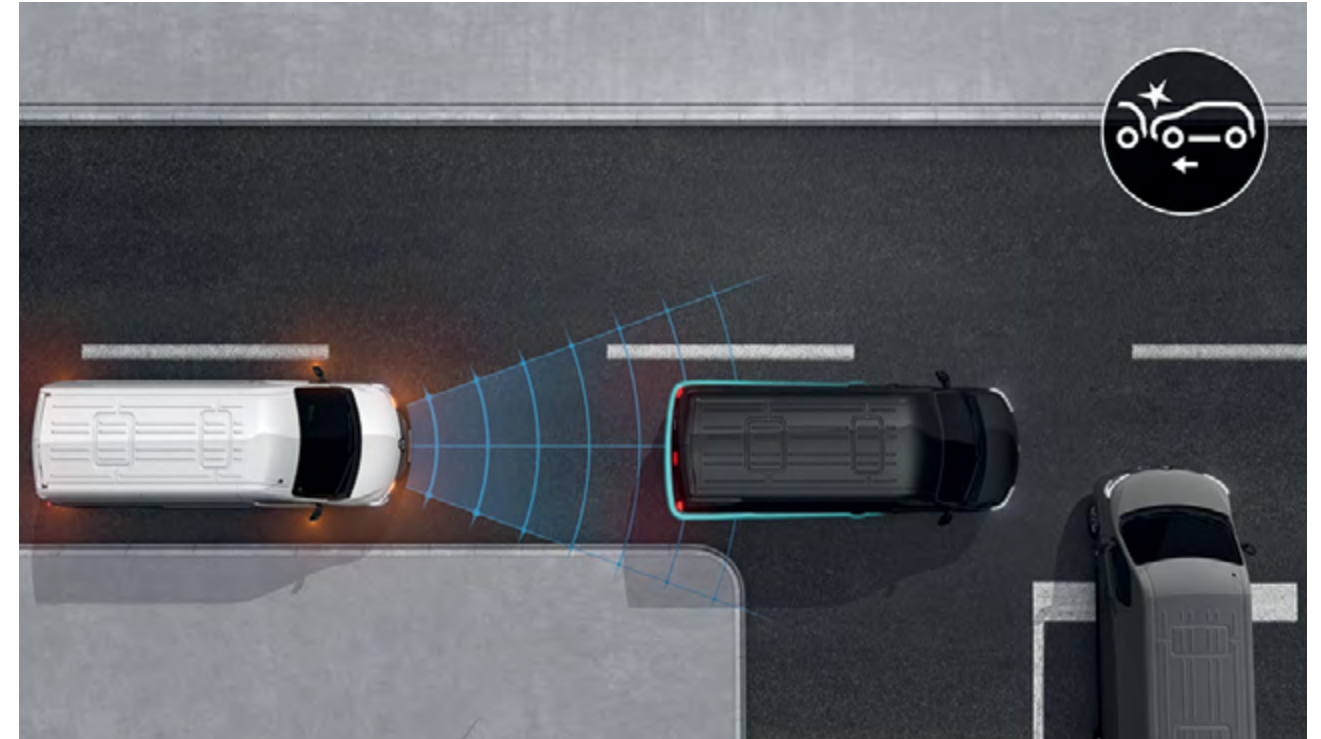

### active emergency braking system\*

This system detects vehicles to the side or in front, and stops the vehicle in the event of any danger.

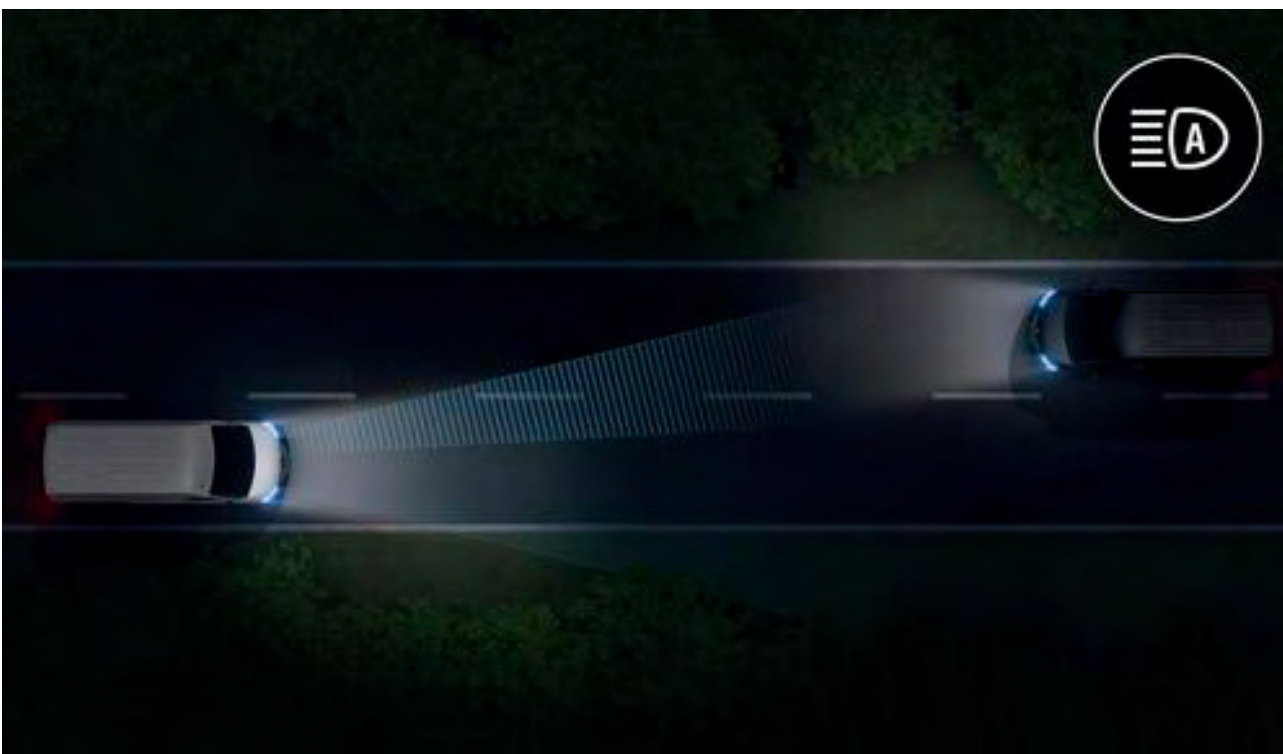

### high-beam assist

Automatically dips the high beams when there is an oncoming vehicle. Once the vehicle has safely passed, the high beams will be reactivated automatically.

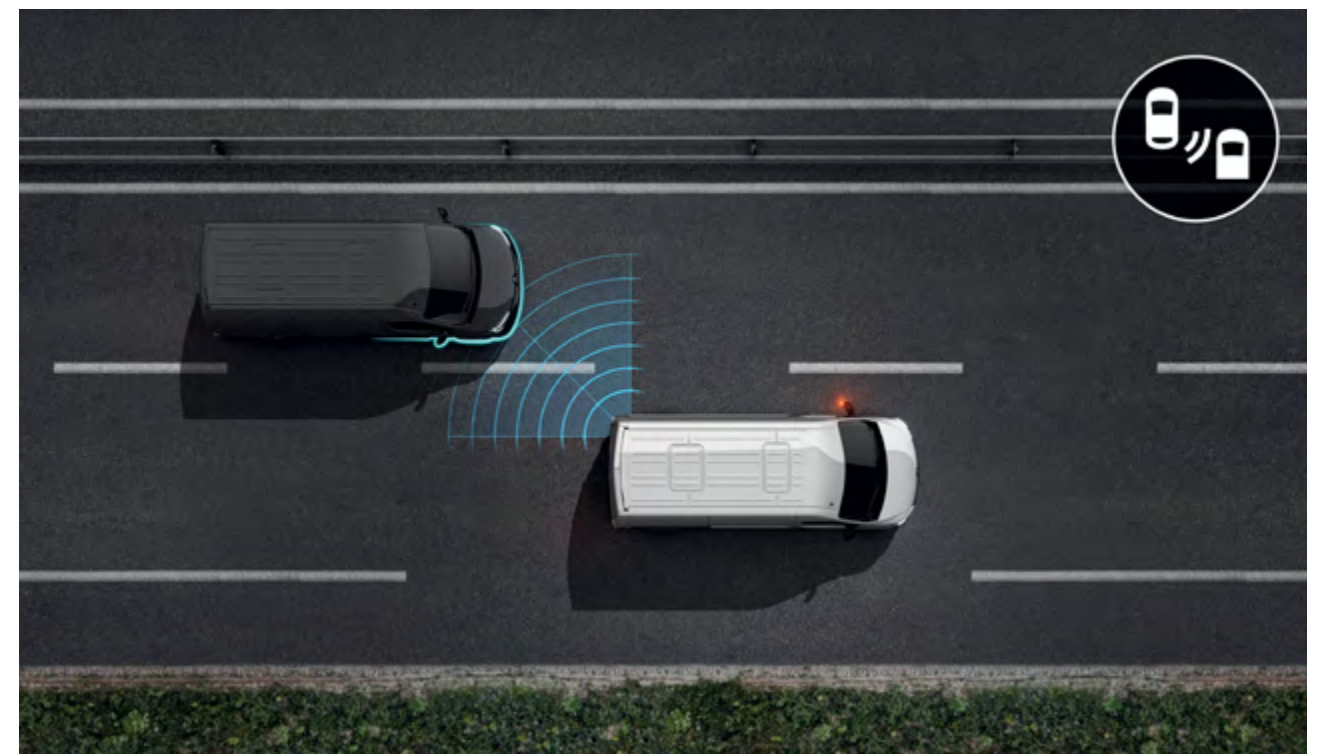

### blind spot warning

Safely change lanes with the help of the blind spot warning system.



### hill start assist

Combined with ESC, hill start assist maintains brake pressure automatically for 2 seconds to give you time to lift your foot from the brake pedal and press the accelerator. The system activates when the slope exceeds 3%.

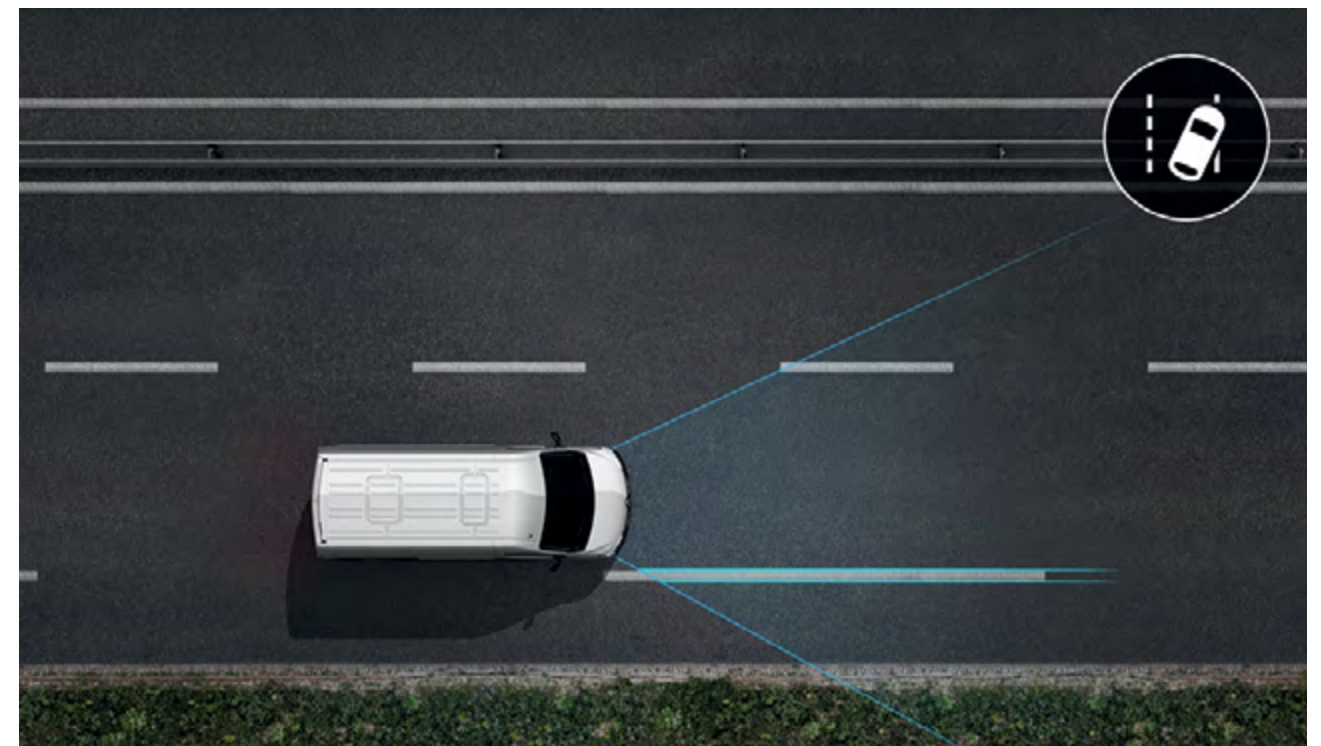

### lane departure warning

The system warns the driver if the vehicle is drifting into another lane unintentionally.

### driver assistance systems

- hill start assist
- high-beam assist
- smart rear-view mirror\*

### park assist systems

- rear parking sensors and camera

### safety assistance

- lane departure warning
- blind spot warning
- electronic stability control (ESC)
- active emergency braking system\*

\*optional

[configure →](#)



## 06. customisation

# colours



**mineral white (s)**



**urban grey (s)**



**star grey (m)**



**tempest blue (m)**



**pearlescent black (m)**

s: solid paint  
m: metallic paint  
photos shown for illustrative purposes  
only

**configure →**



## 06. customisation

# interior trims



- glazed steel bulkhead
- dark grey cloth seat upholstery
- height, reach & lumbar adjustable driver's seat w/ armrest
- dual passenger bench seat w/ fold down centre seat & seat back table
- 7" medianav touchscreen with Apple CarPlay® and Android Auto® replication^

^compatibility may vary depending on phone.

Apple CarPlay® is a trademark of Apple Inc., registered in the U.S. and other countries and regions.

Android Auto™ is a trademark of Google LLC.

# upholstery



**dark grey cloth upholstery**

# wheels



**16" steel wheels with hub cap**



**view specifications here**



## 06. customisation

# options



### **smart rear-view mirror**

The smart mirror displays permanently so you can see what is going on behind you, and improves visibility and safety at all times.



### **LED cargo bay lights**

Included in the optional Trade Pack, the LED cargo bay lights provide a whiter and more intense light to optimise your working conditions.



### **fog lights**

Included in the optional Business Pack, be even more visible on the road with fog lights.

**configure** →



## 06. customisation

# accessories



loading ladder



security mesh



front rubber floor mats

[configure →](#)



## 06. customisation

# engines

| L2H2 MWB<br>FWD MT<br>PRO 120kW                  | L2H2 MWB<br>FWD AMT<br>PRO 110kW                   | L3H2 LWB<br>FWD MT<br>PRO 120kW                  | L3H2 LWB<br>FWD AMT<br>PRO 110kW                   | L3H2 LWB<br>RWD MT<br>PRO 120kW                  | L4H3 ELWB<br>RWD MT<br>PRO 120kW |
|--|--|--|--|--|----------------------------------|
| <b>Engine &amp; Transmission</b>                 |  |  |  |  |                                  |
| <b>Type</b>                                      |  |  |  |  |                                  |
| 2.3L Diesel                                      |  |  |  |  |                                  |
| <b>Capacity (cc)</b>                             |  |  |  |  |                                  |
| 2299   |  |  |  |  |                                  |
| <b>Number of cylinders/ valves</b>               |  |  |  |  |                                  |
| 4/16   |  |  |  |  |                                  |
| <b>Bore x stroke (mm)</b>                        |  |  |  |  |                                  |
| 85 x 101.3                                       |  |  |  |  |                                  |
| <b>Maximum power (kW @ rpm)</b>                  |  |  |  |  |                                  |
| 120 @ 3500                                       | 110 @ 3500   | 120 @ 3500                                       | 110 @ 3500   | 120 @ 3500                                       |                                  |
| <b>Maximum torque (Nm @ rpm)</b>                 |  |  |  |  |                                  |
| 360 @ 1500                                       | 350 @ 1500   | 360 @ 1500                                       | 350 @ 1500   | 360 @ 1500                                       |                                  |
| <b>Fuel type</b>                                 |  |  |  |  |                                  |
| Diesel   |  |  |  |  |                                  |
| <b>Fuel injection type</b>                       |  |  |  |  |                                  |
| Twin-Turbo & Intercooled Direct Injection Diesel | Turbocharged & Intercooled Direct Injection Diesel | Twin-Turbo & Intercooled Direct Injection Diesel | Turbocharged & Intercooled Direct Injection Diesel | Twin-Turbo & Intercooled Direct Injection Diesel |                                  |
| <b>Transmission</b>                              |  |  |  |  |                                  |
| 6 Speed Manual                                   | 6 Speed Automated Manual                           | 6 Speed Manual                                   | 6 Speed Automated Manual                           | 6 Speed Manual                                   |                                  |
| <b>Driven wheels</b>                             |  |  |  |  |                                  |
| Front  |  |  | Rear   |  |                                  |
| <b>Emission standard</b>                         |  |  |  |  |                                  |
| Euro 5   |  |  |  |  |                                  |
| <b>Fuel tank capacity (L)</b>                    |  |  |  |  |                                  |
| 100  |  |  |  |  |                                  |
| <b>Seating capacity</b>                          |  |  |  |  |                                  |
| 3  |  |  |  |  |                                  |
| <b>Overall height (Unladen - mm)</b>             |  |  |  |  |                                  |
| 2499   | 2488   |  | 2549   | 2808   |                                  |
| <b>Kerb weight (kg)</b>                          |  |  |  |  |                                  |
| 1887   | 1977   |  | 2253   | 2363   |                                  |
| <b>Gross vehicle mass (kg)</b>                   |  |  |  |  |                                  |
| 3510   |  |  | 4495   |  |                                  |
| <b>Payload (kg)</b>                              |  |  |  |  |                                  |
| 1623   | 1533   |  | 2242   | 2132   |                                  |
| <b>Front axle load (max - kg)</b>                |  |  |  |  |                                  |
| 1850   |  |  |  |  |                                  |
| <b>Rear axle load (max - kg)</b>                 |  |  |  |  |                                  |
| 2100   |  |  | 3200   |  |                                  |
| <b>Maximum towing weight, braked (kg)</b>        |  |  |  |  |                                  |
| 2500   |  |  | 3000   |  |                                  |
| <b>Maximum towing weight, unbraked (kg)</b>      |  |  |  |  |                                  |
| 750  |  |  |  |  |                                  |
| <b>Maximum towing weight, download (kg)</b>      |  |  |  |  |                                  |
| 200  |  |  |  |  |                                  |

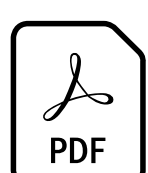

**view specifications here**



## 06. customisation

# configuration diagrams

## closed transportation

### front-wheel drive panel van

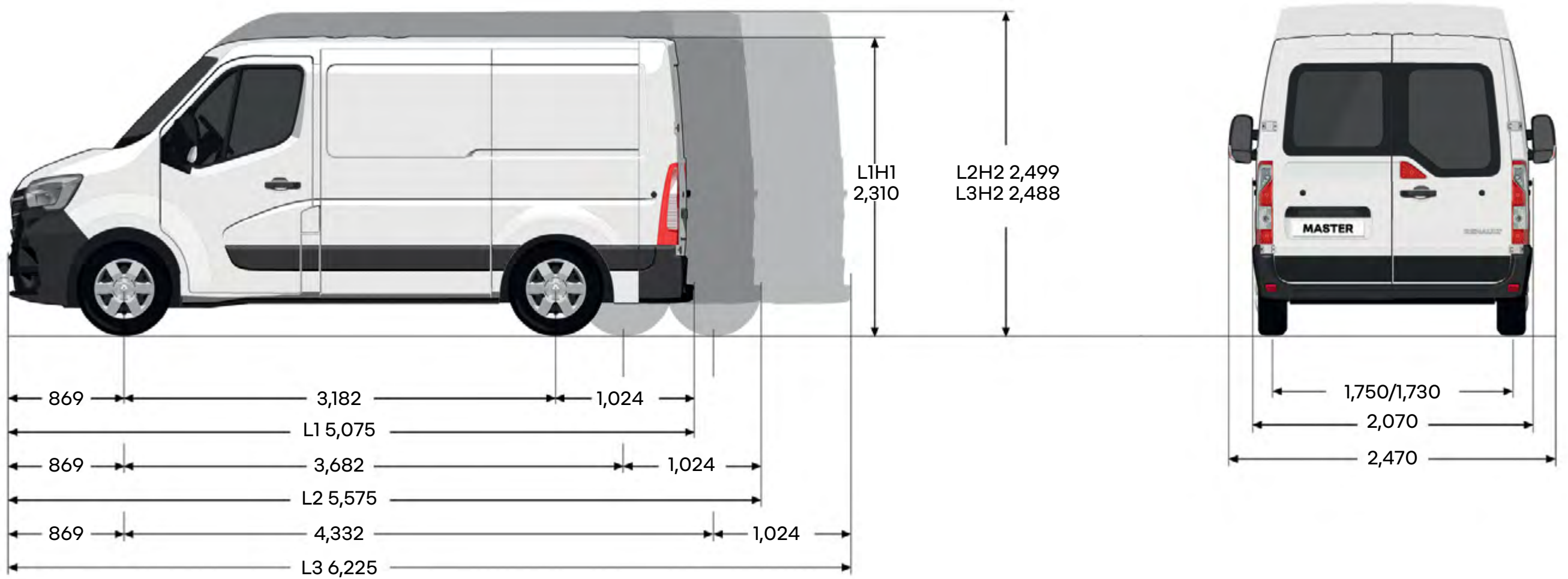

### rear-wheel drive panel van

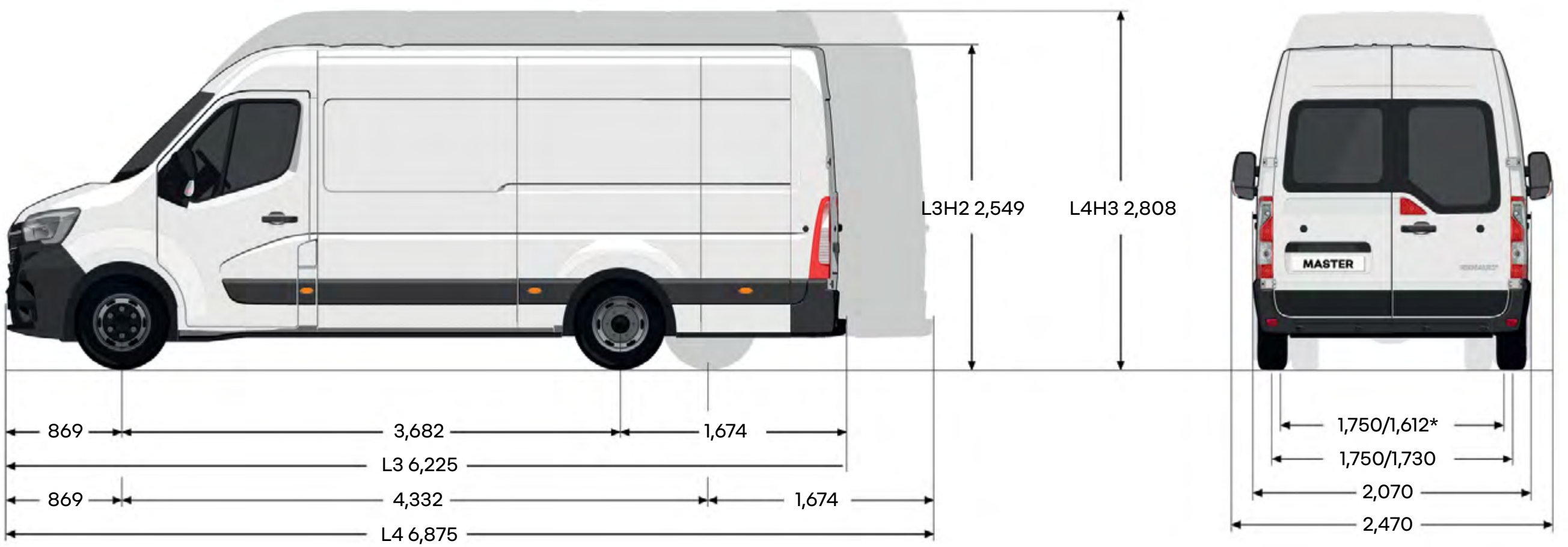

\* twin wheels.

L1H1 technical images included for guidance purposes only. Stock availability is limited, check availability and confirm specifications with your dealer prior to ordering.



[view specifications here](#)

[configure and order →](#)





For more information, call 1800 009 008 or visit [www.renault.com.au](http://www.renault.com.au). Details are correct at the time of publication and are subject to change. Vehicles depicted in this brochure are overseas models and are shown for illustration purposes only; Australian vehicles may differ in features, specifications, equipment, accessories and/or colour. RVDA Pty Ltd reserves the right to discontinue or change its models at its discretion and without prior notice, including features, specifications, equipment, accessories available and colour. The colours in the photographs may vary from actual colours. Please consult your Renault dealer for the latest information on models, features, specifications, prices, options and availability. Publication date - October 2024. RVDA Pty Ltd, 2A Hill Road, Lidcombe NSW 2141. REN1392.



**configure and order →**